



***ESSETI***

**From brass to home  
from brass to you**

  **MADE IN ITALY**

ESSETI nasce nel 1974 e si specializza nella produzione di rubinetti a galleggiante per serbatoi civili e industriali, e per cassette di scarico WC. La progressiva affermazione sia sul mercato nazionale che su quello estero è il risultato dello sforzo continuo per migliorare la qualità e la competitività dei nostri prodotti, ed il crescente successo di questi è stato motivo di ampliamento della gamma di produzione anche ai meccanismi interni delle cassette di scarico WC.

La dimensione equilibrata della nostra azienda ci permette di soddisfare ogni particolare esigenza della clientela, compresa la progettazione e la personalizzazione dei prodotti. L'intera produzione avviene presso il sito di Brandico, su una superficie di circa 2000 metri quadri, con una capacità annuale consolidata di 1,2 milioni di rubinetti a galleggiante e 600000 sfere in plastica.

La rete di vendita si estende dal mercato italiano fino a più di 70 nazioni, con una quota di fatturato estero pari al 75%. Questa forte vocazione all'esportazione trova riscontro anche nella partecipazione a fiere internazionali: Dubai (Big 5 Show) dal 2000; Milano (MCE Expocomfort) dal 1976; Francoforte (ISH Frankfurt) dal 1985.

ESSETI born in 1974 specializing in the production of float valves for civil and industrial tanks, and for toilet uses. Increasing success on domestic and foreign markets is the result of a continuous effort to improve the quality and competitiveness of our products, and cause the extension of our range of articles also to the internal mechanisms for toilet tanks.

The balanced size of our company allows us to completely satisfy any particular requirement of our customers, including design and product customization. An area of about 2000 sq.m. located in Brandico (Italy) comprises the whole production plants and headquarters, with an annual capacity of 1.2 millions float valves and 600 thousands plastic balls.

Currently ESSETI has a global reputation through a worldwide network that reaches more than 70 countries, covering 75% of its sales. The strong export vocation is also reflected in the participation in international exhibitions: Dubai (Big 5 Show) from year 2000; Milan (MCE Expocomfort) from 1976; Frankfurt (ISH Frankfurt) from 1985.

RUBINETTI A GALLEGGIANTE PER  
ABBEVERatoi E APPLICAZIONI SPECIALI  
FLOAT VALVES FOR ANIMAL DRINKERS AND  
SMALL SIZE TANKS

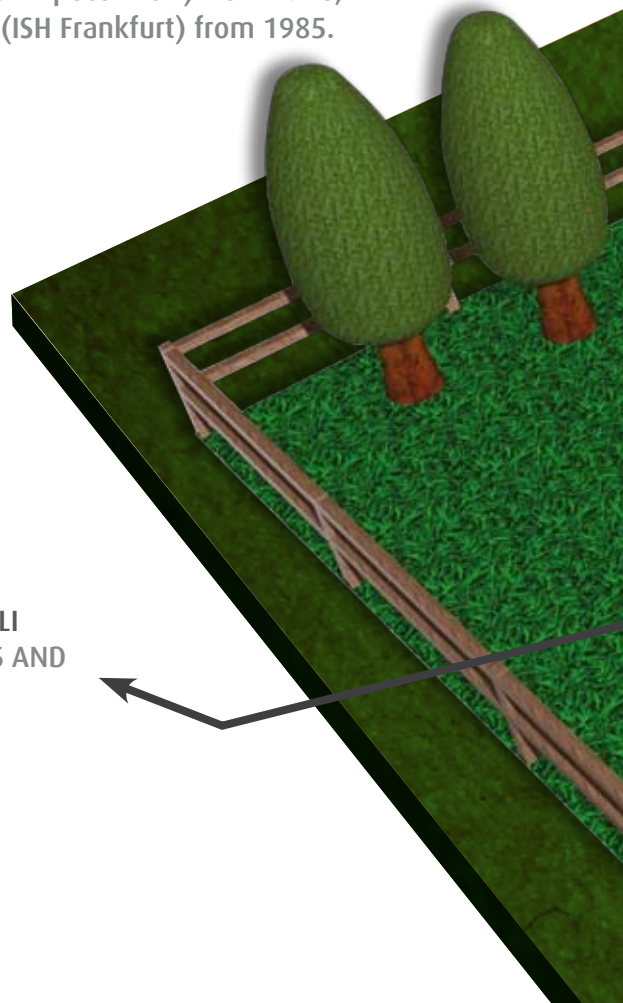

RUBINETTI A GALLEGGIANTE PER CASSETTE WC  
FLOAT VALVES FOR TOILET TANKS

RUBINETTI A GALLEGGIANTE PER SERBATOI E APPLICAZIONI INDUSTRIALI  
FLOAT VALVES FOR TANKS AND INDUSTRIAL USES

MECCANISMI DI SCARICO PER CASSETTE WC  
FLUSH VALVES FOR TOILET TANKS

RACCORDI PER SERBATOI  
TANK FITTINGS

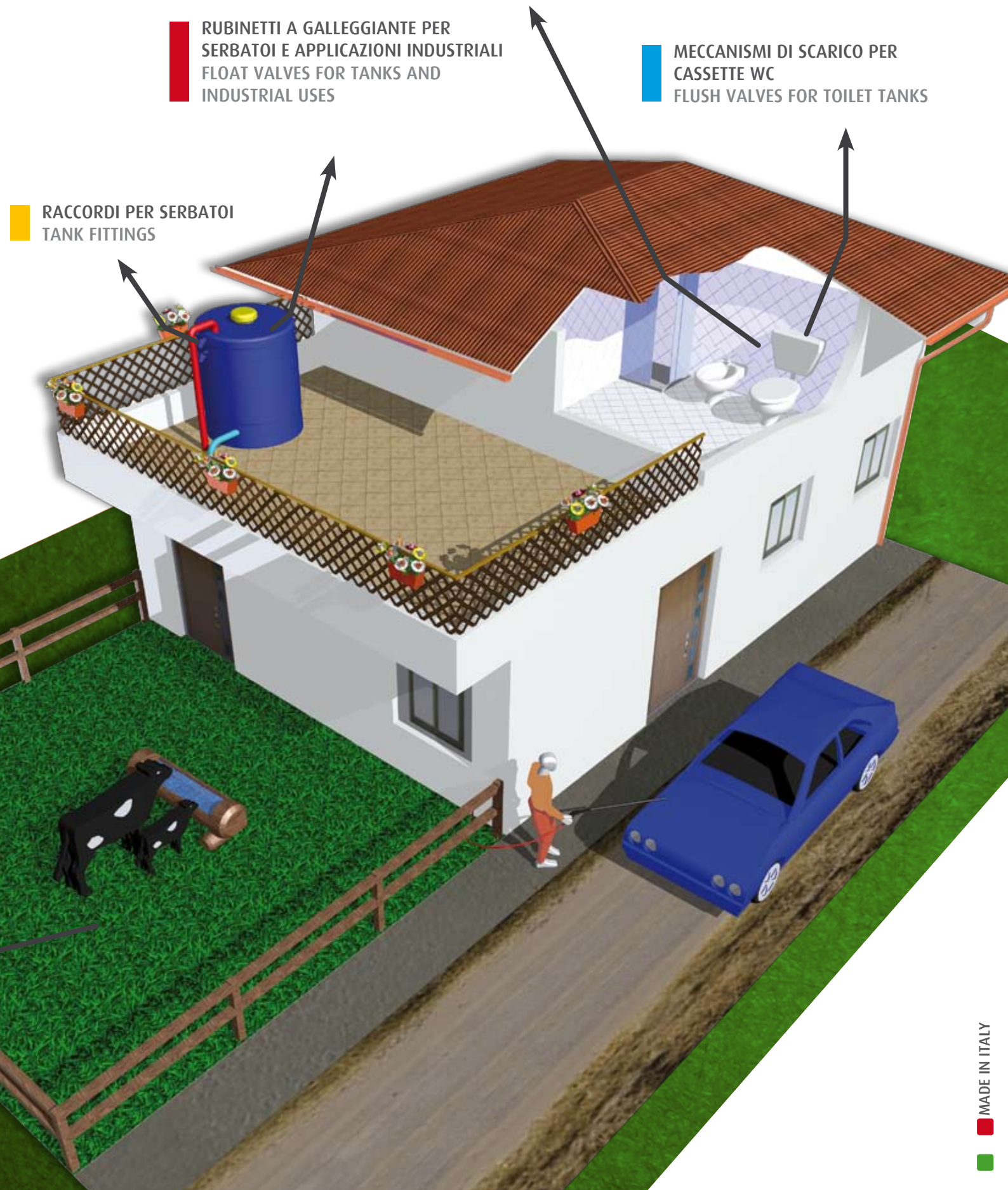

## Float VALVES FOR TOILET TANKS



110

3/8"  
1/2"



215

3/8"  
1/2"



220

3/8"  
1/2"



274

3/8"  
1/2"



421

3/8"  
1/2"



224

3/8"  
1/2"



314

3/8"  
1/2"



315

3/8"  
1/2"



302-C



293

Ø 90  
Ø 120



291

Ø 90



297

Ø 90  
Ø 120

## Float VALVES FOR ANIMAL DRINKERS AND SMALL SIZE TANKS

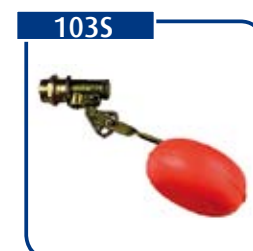

103S

1/2" 1"  
3/4"

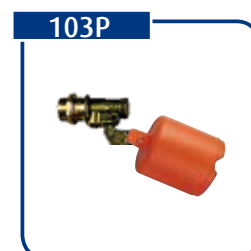

103P

1/2" 1"  
3/4"

## Float VALVES FOR TANKS AND INDUSTRIAL USER

101



(BS1212)  
1/2"  
3/4"  
1"

103



1/2"  
3/4"  
1"

106



1/2"  
3/4"  
1"

104



3/8"	1" 1/4
1/2"	1" 1/2
3/4"	2"
1"	

274



3/8"	1" 1/2
1/2"	2"
3/4"	2" 1/2
1"	3"
1" 1/4	4"

320



1/2"	1" 1/2
3/4"	2"
1"	
1" 1/4	

295



Ø 90	Ø 220
Ø 120	Ø 300
Ø 150	
Ø 180	

296



Ø 3" 1/2	Ø 6"
Ø 4" 1/2	Ø 8"
Ø 5"	

297



Ø 90	Ø 220
Ø 120	Ø 300
Ø 150	
Ø 180	

# Raccordi

PER SERBATOI

## Tank FITTINGS

122A



1/2"  
3/4"  
1"  
1" 1/4

1" 1/2  
2"

123A



1/2"  
3/4"  
1"  
1" 1/4

1" 1/2  
2"

124A



1/2"  
3/4"  
1"  
1" 1/4

1" 1/2  
2"

# Meccanismi

DI SCARICO PER CASSETTE WC

## Flush VALVES FOR TOILET TANKS

Tirante al coperchio  
Entrata laterale e dal fondo  
Pull on Top  
Lateral or bottom inlet

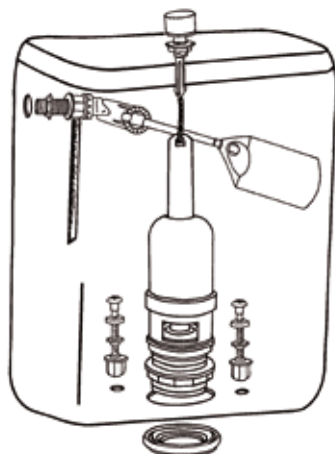

Leva Frontale  
Entrata laterale e dal fondo  
Frontal lever  
Lateral or bottom inlet

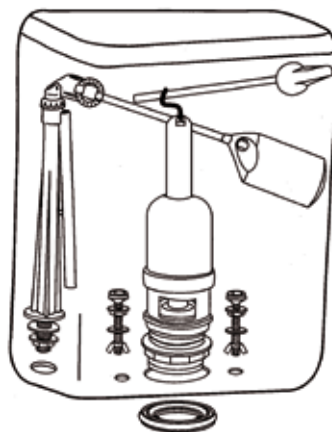

Pulsante meccanico.  
Entrata laterale e dal fondo  
Mechanic push  
Lateral or bottom inlet

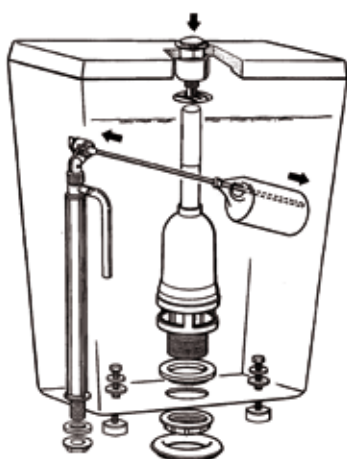

Pulsante pneumatico.  
Entrata laterale e dal fondo  
Air push  
Lateral or bottom inlet

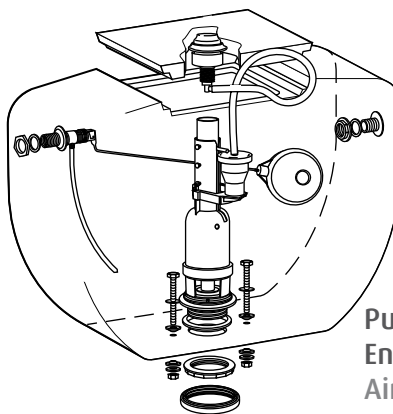

ESSETI

# La Produzione

## The Production



Il reparto produzione e lavorazione ottone ha una capacità annua consolidata di 1,2 milioni di rubinetti a galleggiante.

The annual capacity of our brass working department is of 1.2 millions float valves.



Il reparto lavorazione materie plastiche dispone di macchine a estrusione-soffiaggio e iniezione con una capacità annua di 600000 sfere in plastica.

The plastics processing department offers machines for blow molding and injection molding with an annual capacity of 600 thousands floating balls.



Il reparto di progettazione e sviluppo ci permette di soddisfare ogni particolare esigenza della nostra clientela, compresa la personalizzazione dei prodotti.

The R&D department allows us to completely satisfy any particular requirement of our customers, including product customization.



# From brass to home from brass to you

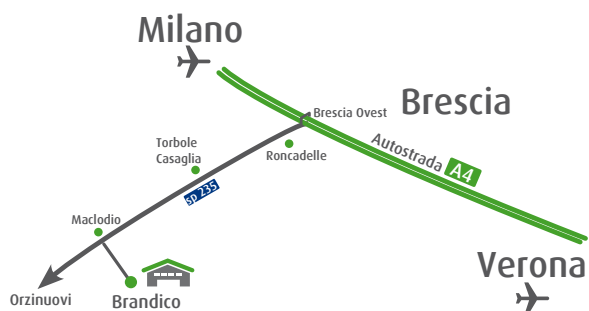

ESSETI s.r.l.  
Via Enrico Fermi, 64 25030  
Brandico (Brescia) Italy

Tel. +39 030 975115  
Fax +39 030 975891  
email: [info@esseti-srl.com](mailto:info@esseti-srl.com)  
Web: [www.esseti-srl.com](http://www.esseti-srl.com)

MADE IN ITALY